

4" 95 PR18
95 PRX18
95 PRG18



CARATTERISTICHE IDRAULICHE - HYDRAULIC PERFORMANCES

Q= Portata - Capacity - Debit **50 Hz n= 2900 min**

Tipo Type	Power		V230 Single Phase		V400 Three Phase A	H(m)	0	150	200	250	300	350	400	
	kW	HP	A	µF			l/min	l/sec	l/min	l/min	l/min	l/min	l/min	l/min
							m ³ /h	0	2,50	3,33	4,17	5	5,83	6,67
95 PR18 N/05	1,1	1,5	9,4	40	3	28	22	19	17	14	9	2,2		
95 PR18 N/07	1,5	2	11,5	50	4	39	30	27	24	19	12	3,1		
95 PR18 N/10	2,2	3	14,7	75	5,7	56	43	39	34	27	17	4,4		
95 PR18 N/14	3	4	-	-	7,4	78	61	54	48	38	24	6		
95 PR18 N/19	4	5,5	-	-	10	106	82	74	65	52	33	8		
95 PR18 N/23	5,5	7,5	-	-	13,5	128	100	89	79	63	40	10		
95 PR18 N/32	7,5	10	-	-	18	178	139	124	110	87	55	14		

DIMENSIONI D'INGOMBRO E PESI - OVERALL DIMENSIONS AND WEIGHTS

Type	A mm Single Phase V 230	A mm Three Phase V 400	B mm	C mm Single Phase V 230	C mm Three Phase V 400	M Kg Single Phase	M Kg Three Phase	P Kg
95 PR18 N/05	967	937	575	392	362	12	12	5
95 PR18 N/07	1143	1113	721	422	392	13	13	6
95 PR18 N/10	1407	1392	940	467	452	15	15	8
95 PR18 N/14	-	1789	1232	-	557	-	19	10
95 PR18 N/19	-	2194	1597	-	597	-	22	13
95 PR18 N/23	-	2587	1889	-	698	-	27	16
95 PR18 N/32	-	3364	2546	-	818	-	32	21

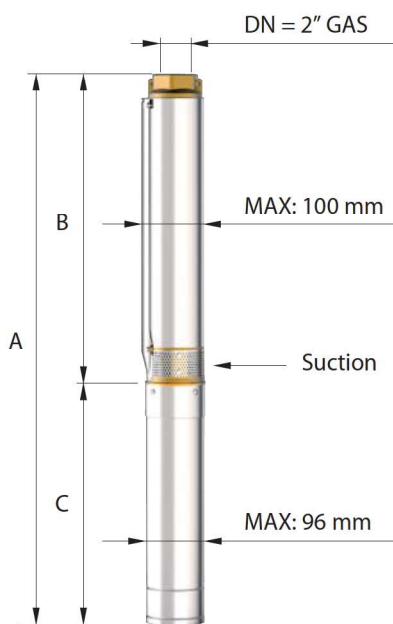

Versioni disponibili
Available versions
Versions disponibles
Versiones disponibles



95 PR
Gabbia di aspirazione e mandata in ottone
Suction cage and delivery bowl in brass



95 PRX
Gabbia di aspirazione e mandata in AISI 304 microfuso
Suction cage and delivery bowl in AISI 304 casted



95 PRG
Gabbia di aspirazione e mandata in ghisa con trattamento di cataforesi
Suction cage and delivery bowl in cast iron with CED (Cathode Electro Deposition)

n% = Rendimento della pompa
n% = Rendement de la pompe
n% = Pump efficiency
n% = Rendimiento de la bomba

Max 64,5%

kW/st = Assorbimento per stadio
kW/st = Absorption par étage
kW/st = Stage absorption
kW/st = Potencia absorbida por etapa

Max 0,216

Tolleranze secondo UNI ISO 9906 livello 3B - Tolerances according to UNI ISO 9906 grade 3B



4" 95 PR18
95 PRX18
95 PRG18

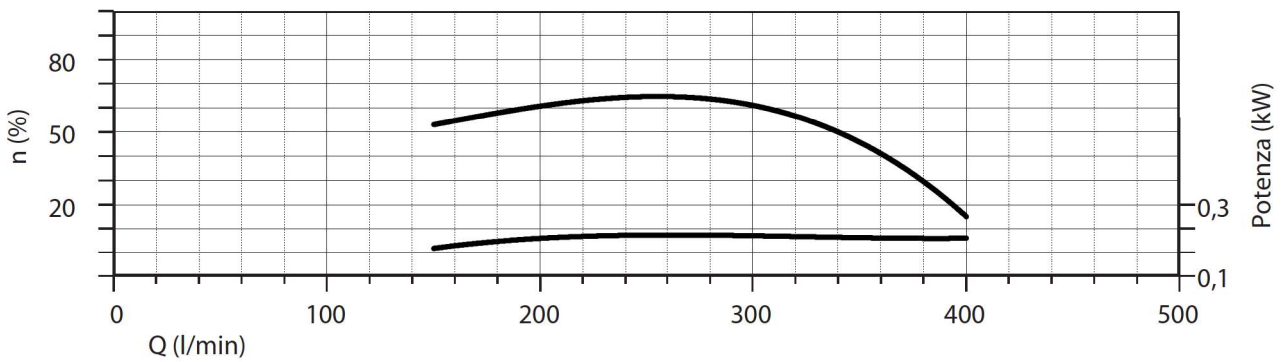
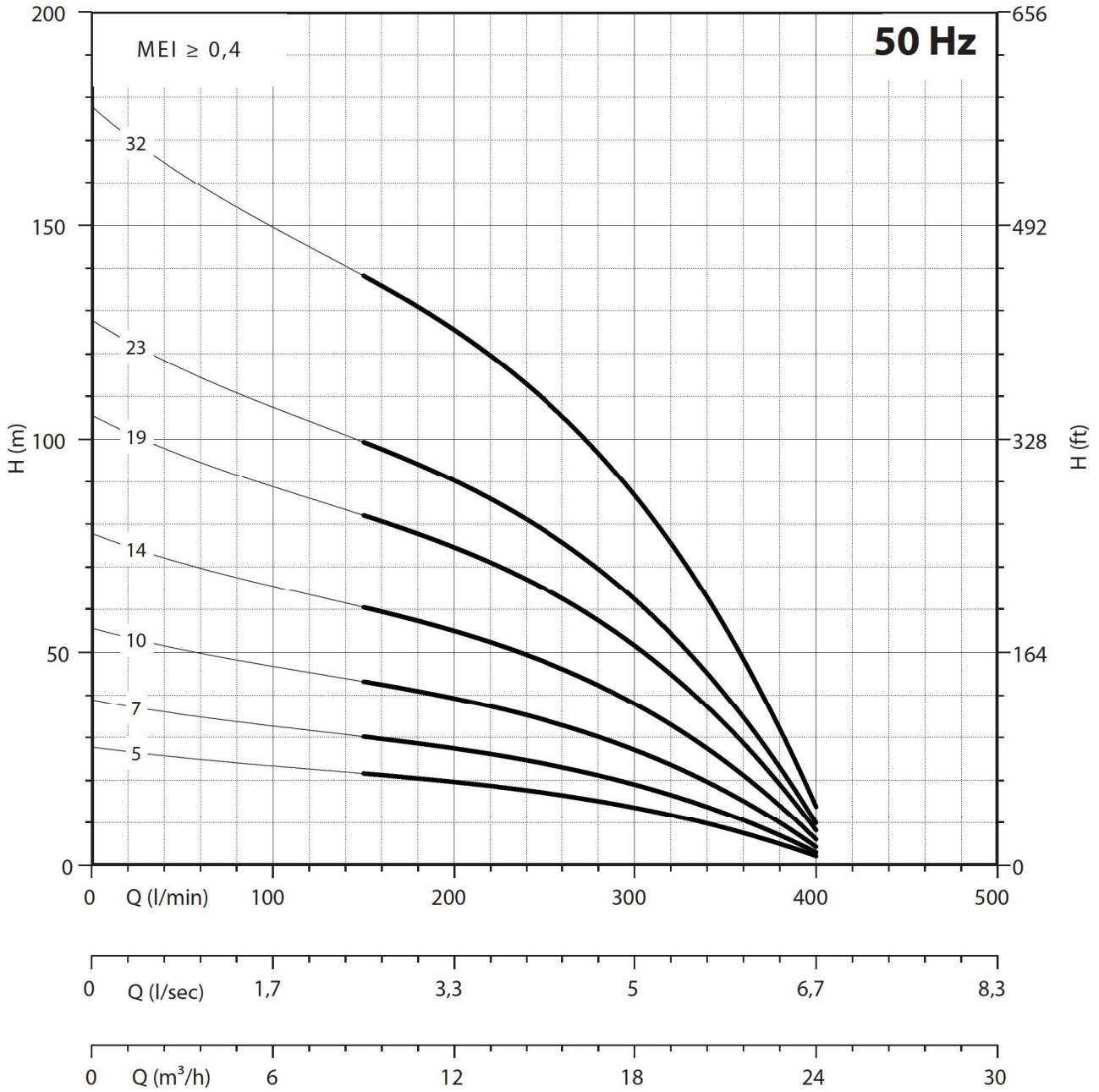

NPSH (m)	25%	50%	75%	100%
95 PR 18 - 95 PRX 18 - 95 PRG 18	3	3	4	6